

Jacketed and insulated floor mounted safety shower

EXP-EJ-5GS

A floor mounted emergency safety shower with pre-insulation and outer jacket to protect the pipework from direct sunlight. Once activated using the pull handle the safety shower will deliver a minimum flow rate of 76 litres per minute of water to effectively decontaminate the casualty. Designed to meet EN15154 and ANSI Z358.1-2014 standards.



Shown with optional sign

Specifications

MATERIALS OF CONSTRUCTION	
PIPEWORK & FITTINGS	Stainless steel
OPERATING VALVE	Stainless steel, full bore, stay open ball valve
SHOWER NOZZLE	Injection moulded nylon 6
INSULATION & OUTER CASING	Polyurethane foam insulation with a medium density polyethylene impact resistant outer casing
SERVICES	
WATER INLET	1¼" male BSP
OPERATING PRESSURE	2 to 6 BAR G / 29 to 87 PSI (higher supply pressures accommodated with the incorporation of the optional pressure reducing valve)
MINIMUM FLOW RATES	Shower: 76 L per minute / 20 US gal per minute
AMBIENT OPERATING TEMPERATURE	
MINIMUM	0C / 32F
MAXIMUM	55C / 131F
OPERATION	
SHOWER	Pull handle
DIMENSIONS & WEIGHT	
DIMENSIONS (WxDxH)	210mm (8.3in) x 890mm (35in) x 2330mm (91.7in)
WEIGHT	19kg (42lb)

General Arrangement Drawing

Jacketed and insulated floor mounted safety shower

EXP-EJ-5GS

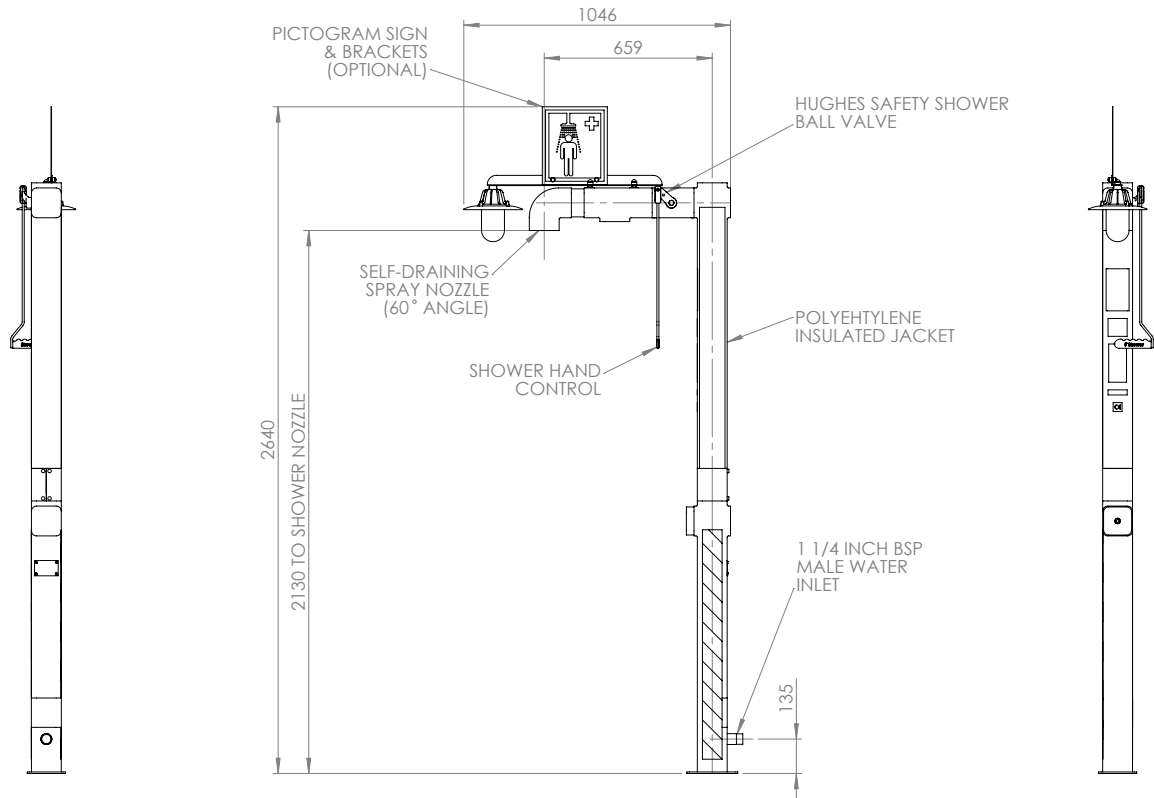

FIXING DETAIL VIEW

