

# Product Datasheet

## Hughes Zero Power Cooler®

### TS Chiller ZPC

Designed in collaboration with



Award winning cooling option for emergency tank showers to temper the water within the tank in hot ambient climates, without the need for power!

EN15154 and ANSI Z358.1-2014 standards state that water delivered by a safety shower should be tepid. In extreme hot climates solar radiation can heat water within the tank to dangerous levels. The Hughes Zero Power Cooler, designed in collaboration with Celantel, uses the night time ambient temperature to maintain the daytime temperature of the water, ensuring the delivery of safe and tepid water.

- Perfect for remote locations, no power or electricity required
- Maintenance free - no moving parts means expensive service options are a thing of the past
- Environmentally friendly
- Retrofittable to your existing Hughes tank showers



## Specifications

MATERIALS OF CONSTRUCTION	
EXTERNAL EXCHANGER	Piping: Copper / Fins: Aluminium / Painting: Cataphoretic coating
INTERNAL EXCHANGER	Piping: Stainless Steel / Flanges: Stainless Steel
COOLANT MEDIUM	H <sub>2</sub> O
SERVICES	
POWER RATING	No power required
LOCATIONS SUITABLE FOR USE	Suitable for use in areas classified as hazardous and non-hazardous
AMBIENT OPERATING TEMPERATURE	
WATER TEMPERATURE	Night-time average air temperature + 2C / 36F
MAXIMUM WATER INLET TEMPERATURE	See commissioning time table below
DIMENSIONS & WEIGHT	
DIMENSIONS (WxDxH) - cooling unit (Internal and external)	1188mm (46.7in) x 1188mm (46.7in) x 1765mm (69.5in)
DIMENSIONS (WxDxH) - installed on 1500L tank shower	1420mm (55.9in) x 1495mm (58.9in) x 4274mm (168.2in)

Inlet Water Temperature	Commissioning Time - Days						
	22°C	24°C	26°C	28°C	30°C	32°C	34°C
60°C	3	3	3	4	4	5	6
55°C	2	2	3	3	4	4	5
50°C	2	2	2	3	3	3	4
45°C	1	1	1	2	2	2	3
40°C	1	1	1	1	1	1	1
Night Air Temperature	22°C	24°C	26°C	28°C	30°C	32°C	34°C

# General Arrangement Drawing

## Hughes Zero Power Cooler®

TS Chiller ZPC

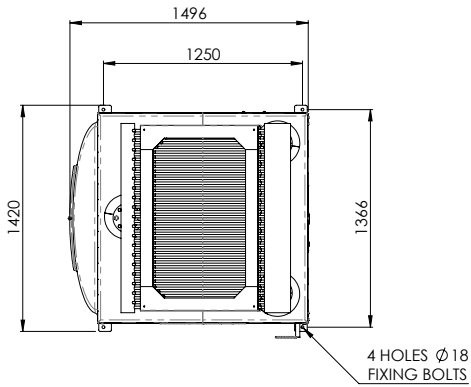
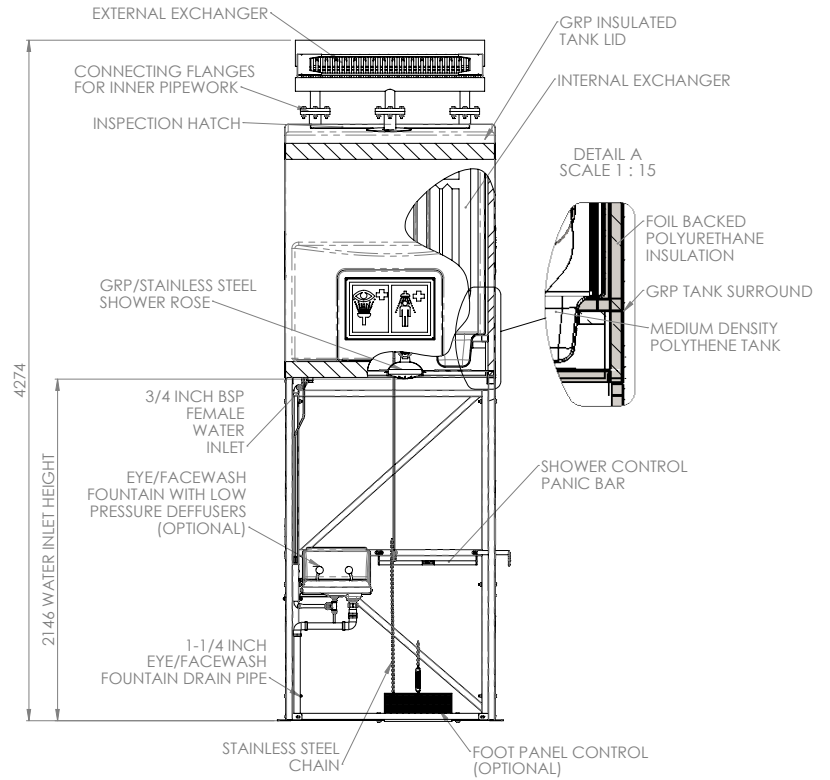
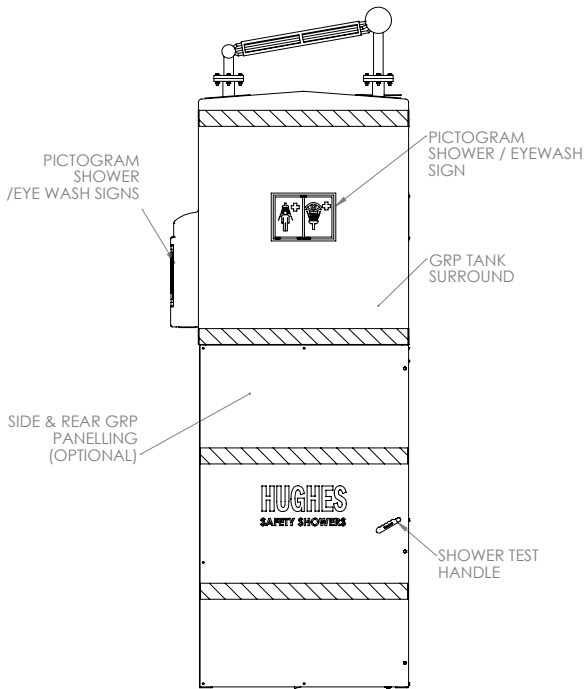

**Hughes Zero Power Cooler®**  
 Patent Approved  
 Pat. US 12,209,808 B2